

5VI300XP

60 cm dishwasher

Integrated - Stainless steel



5VI300XP Stainless steel

- Capacity: 12 place settings
- Energy Efficiency Class: A+
- Energy consumption in programme Eco 50: 290 kwhper year, based on 280 standard cleaning cycles using cold water fill and the consumption of the low power modes. Actual energy consumption will depend on how the appliance is used.
- Energy consumption in programme Eco 50: 1.02 kwh
- Power consumption off-mode / left-on mode: 0.1 W / 0.1 W
- Water consumption in programme Eco 50: 3360 litres per year, based on 280 standard cleaning cycles. Actual water consumption will depend on how the appliance is used.
- Water consumption in programme Eco 50: 12 l
- Drying efficiency class A on a scale from G (least efficient) to A (most efficient)
- The information relates to the programme Eco 50. This programme is suitable to clean normally soiled tableware and is the most efficient programme in terms of combined energy and water consumption.
- Programme time in programme Eco 50: 210 min
- Duration of the left-on mode: 0 min
- Noise level: 54 dB(A) re 1 pW
- Integrated
- 3 programmes: Normal 65 °C, Eco 50 °C, Pre Rinse
- 2 cleaning temperatures
- Flow-through water heater with integrated pumping system
- DosageAssist
- BLDC drive
- Load-Sensor
- Detergent Automation
- Alternating spray
- Regenerative electronics
- Self-cleaning filter system with 3-fold corrugated filter
- Interior tub material: Stainless Steel/Polinox
- LED programme status indicator
- Colour of LED: red
- LED salt refill indicator
- LED rinse-aid refill indicator
- Cutlery basket in bottom basket
- 2 cup shelves in top basket
- Glass holder in top basket
- Multiple water protection
- Maximum inlet water temperature: 25°C
- ServoLock
- Glass care system
- Front-adjustable rear foot
- Incl. Steam protection plate
- Product dimensions (HxWxD): 81.5 x 59.8 x 57.3 cm

4251003100686



5VI300XP

60 cm dishwasher

Integrated - Stainless steel

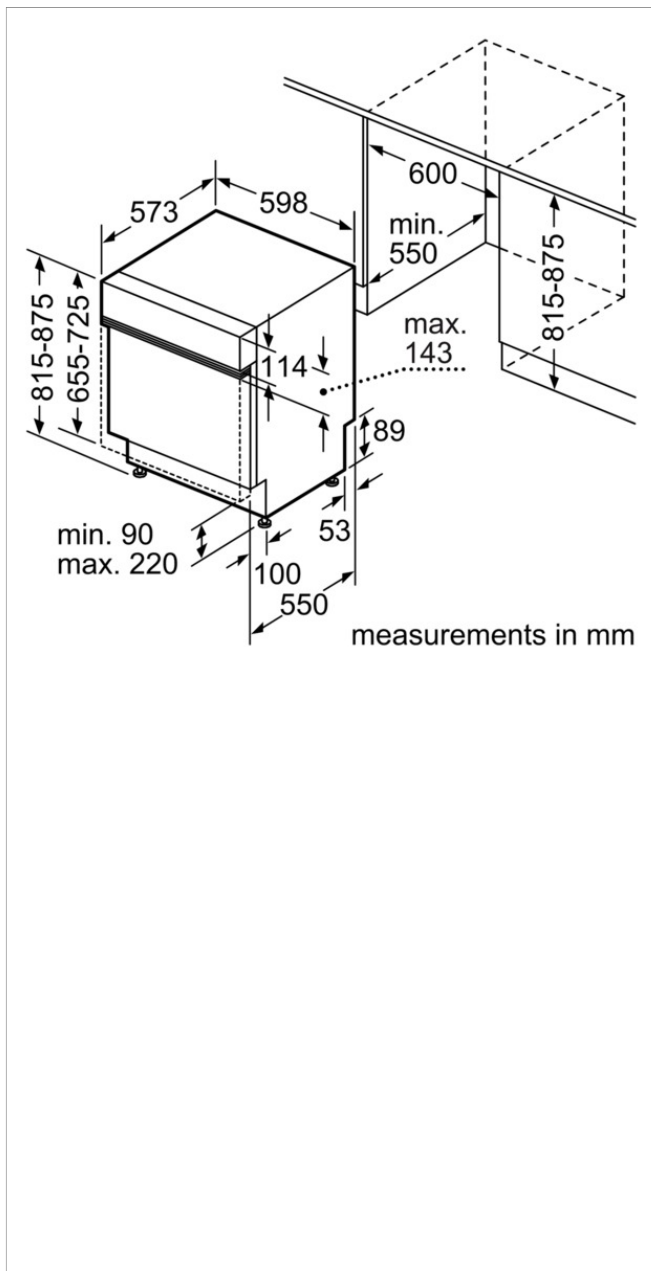

Characteristics

Cleaning performance: A
Water consumption (l): 12.0
Built-in / Free-standing: Built-in
Removable top: No
Door panel options: Not possible
Height with worktop (mm): 815
Height of the product (mm): 815
Adjustable feet: Yes - front only
Maximum adjustability feet (mm): 60
Net weight (kg): 36.0
Gross weight (kg): 38.0
Connection Rating (W): 2400
Current (A): 10
Voltage (V): 220-240
Frequency (Hz): 50; 60
Length electrical supply cord (cm): 175
Plug type: GARDY plug w/ earthing
Length inlet hose (cm): 165
Length outlet hose (cm): 190.0
Hidden heating element: Yes
: No
Water softener (kWh): Yes
Top basket type: Normal
Adjustable upper basket: No
Upper rack cup shelf: 2
Bottom basket type: Normal
3rd Rack: None
Silverware Basket: Standard
Included accessories 2: vapor barrier plate
Number of place settings: 12
Color / Material panel: Stainless steel
Color / Material body: Lacquered

Consumption and connection features

Brand: Blaupunkt
Product name / Commercial code: 5VI300XP
Number of place settings: 12
Energy efficiency class (2010/30/EC): A+
Energy consumption annual (kWh/annum) - NEW (2010/30/EC): 290
Energy consumption (kWh): 1.02
Power consumption in left-on mode (W) - NEW (2010/30/EC): 0.10
Power consumption in off-mode (W) - NEW (2010/30/EC): 0.10
Water consumption annual (l/annum) - NEW (2010/30/EC): 3360
Drying performance: A
Reference programme: Eco
Total cycle time of reference programme (min): 210
Duration of the left-on mode - NEW (2012/30/EC) (min): 0
Noise level (dB): 54