

Framed opening height = $1\frac{7}{8}" + Y + \text{Panel} + \frac{7}{16}"$

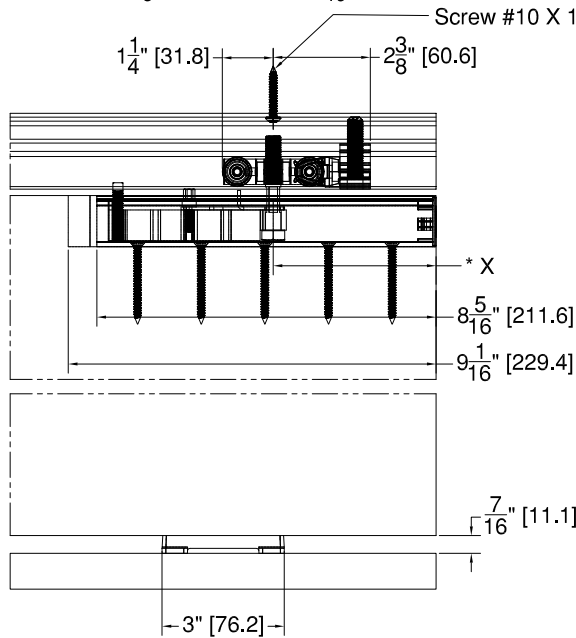

*X = 3" [76.2 mm] for use with Grant SD 5' or 7' track
*X = 4" [101.6 mm] for use with all other Grant SD track lengths

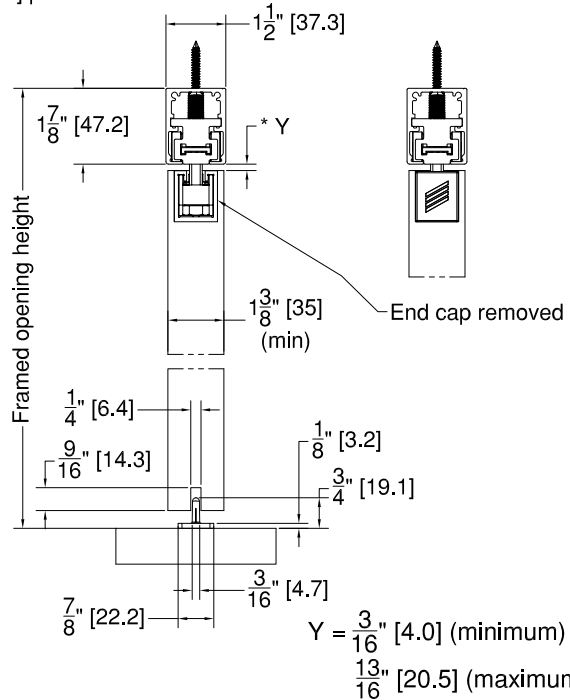

Note:

- For bi-parting doors use an additional set of hardware.
- For bypassing doors mount parallel tracks.
- These instructions assume a properly framed opening with a carefully leveled header.
- It is recommended to pre-drill all screws.

1 Door preparation

Cut a pocket in the top of the door as shown (both sides). Cut a groove in the bottom of the door (the entire door length).

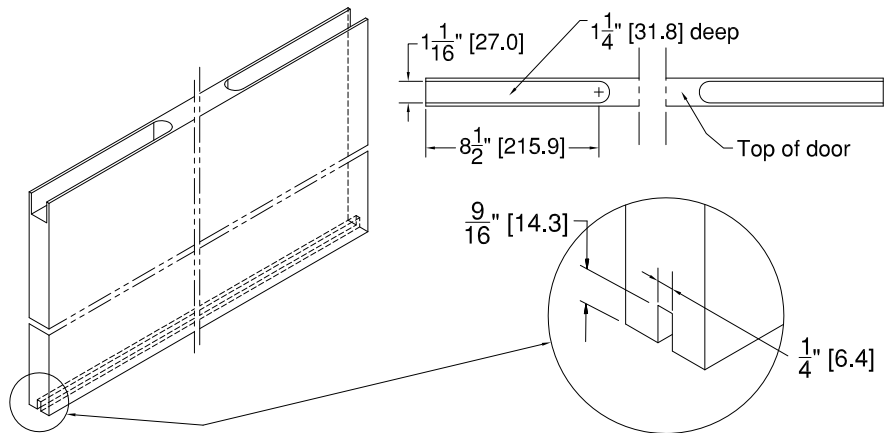

2 Aluminum channel housing

Loosen square head set screw with the wrench provided. Slide carrier assembly out of the aluminum channel housing. Fit channel housing into pocket and mount with (5) #10 X 2" flat head screws provided (use plastic end cap to assure channel is flush with the door edge). Repeat for other side.

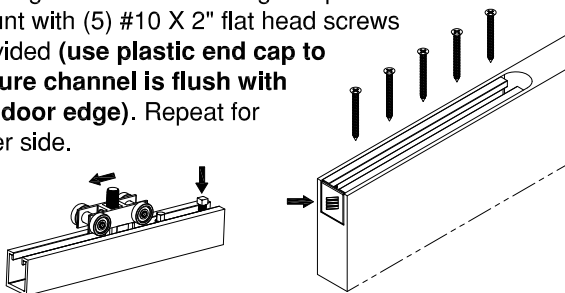

3 Endstop holder / carrier

Slide endstop holders and carriers into the track. Securely tighten endstop holder in position using a 3/16" hex key. Torque to 25-30 ft-lbs.

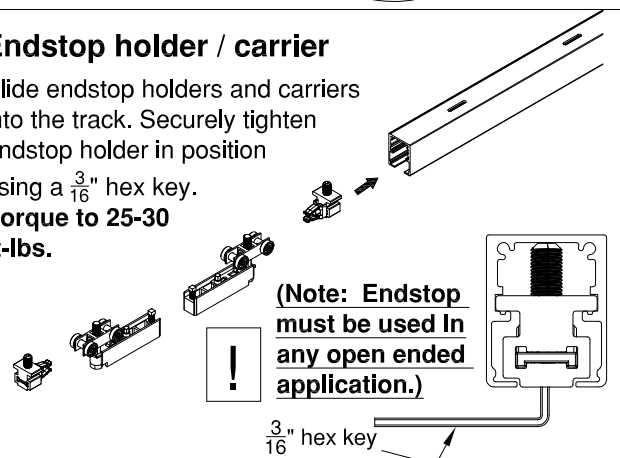

4 Track

Secure the track into position using #10 x 1 ¹/₄" pan head screws every 8". (**Note: if track is cut it MUST be insured that the last mounting screw is no more than 4" from the end of the track.**)

4" [101.6] or less

5 Floor guide

Align floor guide vertically with the center of the track and fasten with (4) #6 x ³/₄" screws provided.

3" [76.2]

³/₁₆" [4.8]

6 Mount door

Slide carrier unit assembly insert into aluminum channel (both sides). **Note: orientation of carrier.**

9 Door height adjustment

A) Loosen hex head locking screw with wrench provided

B) Using bent up tab, slide locking plate back to disengage from adjustment bolt flats. **Adjustment bolt cannot be turned while locking plate is engaged with flats without damaging the system.**

Adjustment bolt
Locking plate
Slide

C) Turn adjustment bolt to raise or lower door

D) Align locking plate with flats of adjustment bolt and slide forward using bent up tab. Tighten hex head locking screw to secure locking plate. **Snug, do not overtighten.**

Slide

7 Secure door

Adjust center of pendant (adjustment) bolt to the correct dimension from the door edge (refer to the main figure on page 1). **Important: Tighten square head locking screw securely using the wrench provided, both sides.**

(If door needs to be lowered to be able to access the square head locking screw, follow the door height adjustment instructions in step 9.)

8 End cap

Insert plastic end cap to cover the hardware (both sides).

Warning

The Top Line Grant SD/LP Series door system ("Door System") is designed to support cabinets, storage walls, or doors weighing up to 150 lbs. (68 kg). The Door System must be installed by attaching it to a framing member that is designed to support 150 lbs. (68 kg) plus the weight of the Door System ("Total Support Weight"). Improper installation of the Door System, including, but not limited to, the use of unauthorized hardware, or the failure to install the Door System by attaching it to a framing member that is designed to support the Total Support Weight, could result in serious injury or death. **DO NOT INSTALL THE DOOR SYSTEM TO A FRAMING MEMBER THAT IS NOT DESIGNED TO SUPPORT AT LEAST THE TOTAL SUPPORT WEIGHT. INSTALL THE DOOR SYSTEM ONLY IN THE MANNER SET FORTH IN THE DOOR SYSTEM'S DOOR HARDWARE INSTALLATION INSTRUCTIONS.**